

1963 VW Beetle—Electric Vehicle Conversion

USD EV

Glenn Moss | Rafael Brennand | Peter Brown | George Delisle

Faculty Sponsor: Dr. Daniel Codd & Dr. Venkat Shastri



Abstract:

Issue:

As the issues with the environment continue to grow, cities around the world are beginning to implement bans on internal combustion engines. This means that older cars and classics will now be confined to a garage or showroom instead of being enjoyed from the driver's seat.

Our Solution:

To design, fabricate, and test the practicality of a modular conversion process of an internal combustion vehicle to an electric vehicle. This process can be applied to pre-smog vehicles and other classics so they can be enjoyed by their owners on the road again, just as they were meant to be.

Key Requirements:

Modularity: Electric drivetrain must be implemented on a certain range of Volkswagen chassis models

Cost: Conversion cost < \$15,000
Operating Cost: 7¢/mile (vs 14¢/mile for IC)

Performance: Improve 0-60 time by 14 seconds

Efficiency: 4.12 miles per kWh

Range: Greater than 50 mi.

Survey Results:

What do you think are the benefits of owning an electric car?

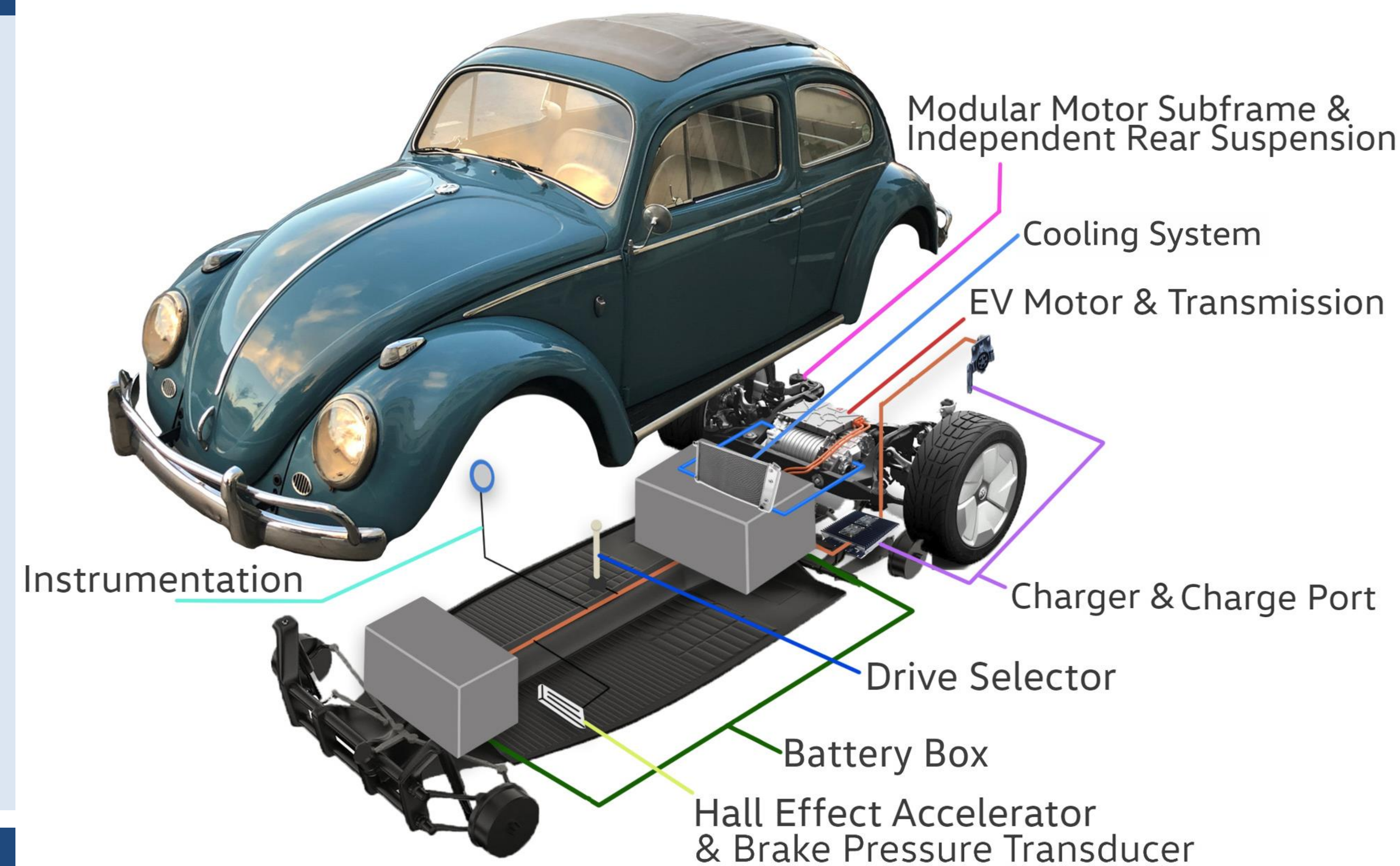
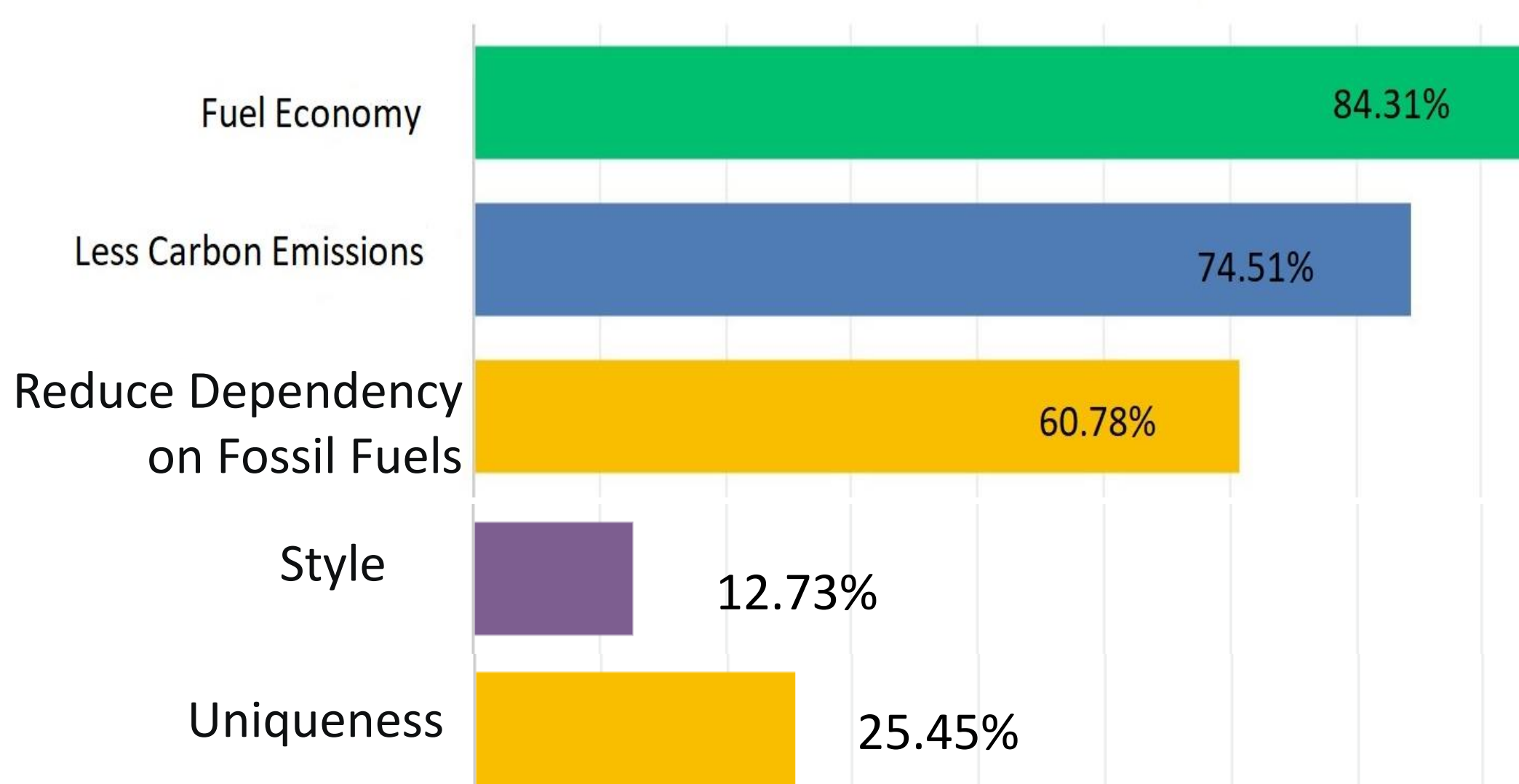

Functional Schematic:

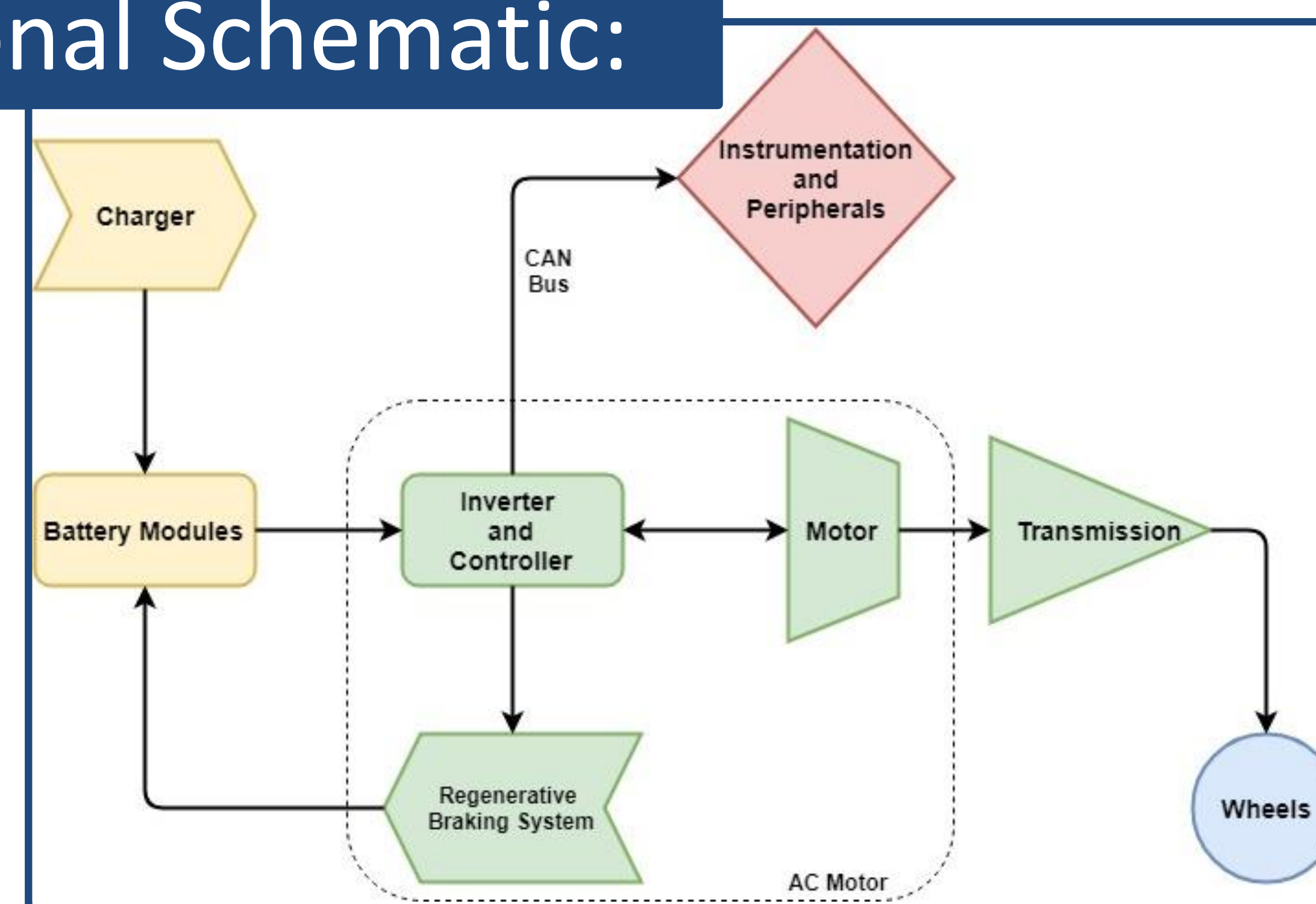

Battery Box Design:

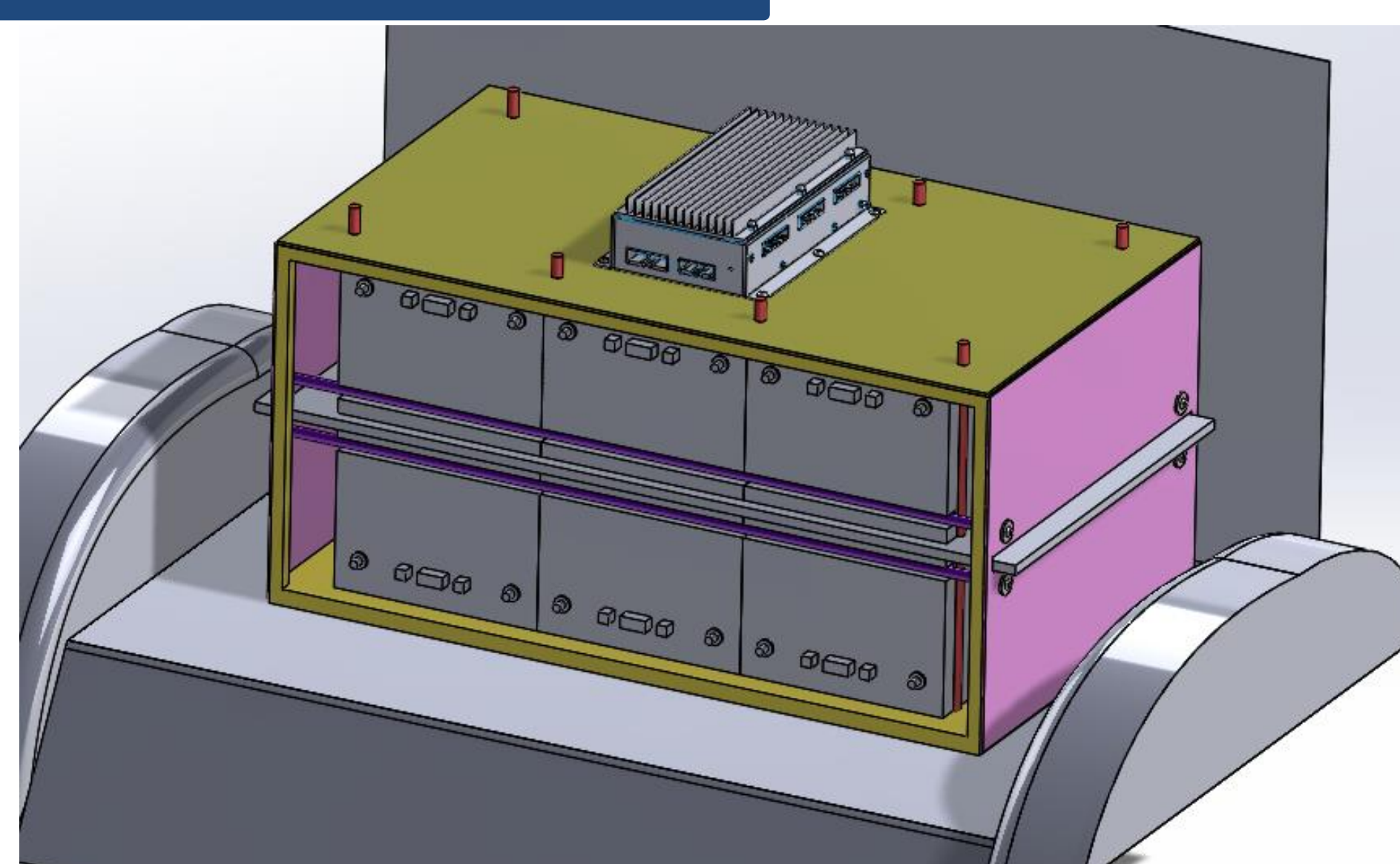

Subsystems:

1. AC Motor

- 3-phase AC induction motor
- High Reliability, Modern Performance
- Water cooling system

2. IRS Mounting System

- Independent Rear Suspension (IRS) used to adapt new transmission
- Modular mounting system for installing AC motor on vehicle chassis

3. Battery Management System

- Temperature controller for batteries

5. Battery Charging System

- Charger capable of charging with either 240v or 120v
- Compatible with modern charge port standards

6. Cooling System

- Radiator for water cooling of the motor
- Heat sinks for air cooling of batteries

6. Motor Controller

- Control system for running the motor, brakes, regenerative brakes, and other vehicle peripherals

Specifications:

Battery: 15 kWh LG Chem Batteries
96s configuration

Motor: 250 kW Rear Drive Tesla Motor

Controller: Tesla Embedded Controller & Inverter

Suspension: Double Wishbone (A-arm)
Independent Rear Suspension

Transmission: Single Speed Tesla Transmission

Meet the Team:

Glenn Moss: ME, **George Delisle:** EE,
Peter Brown: EE, **Rafael Brennand:** ME